

kassow robots  
strong · fast · simple

Joining forces with

rexroth  
A Bosch Company



# KR Series

Strong, fast, simple. Meet the 7-axes industrial cobot.



Payload  
up to **18 kg**



Reach  
up to **1800 mm**



Speed  
up to **225°/s**

# Unlock your potential

## Automate your operations with Kassow Robots.

Revolutionize your manufacturing process by integrating robotics into your production line. Boost productivity with tireless automation, ensuring precision, consistency, and accelerated workflows.

A unique combination of the 7th axis, payload & reach. From 5 to 18 kg and a reach of 850 to 1800 mm – all delivered at joint speeds of up to 225 degrees per second: Our range of 5 models allows to reach around the corners, and undertake the most demanding manufacturing tasks.



Plug-in configuration



Intuitive user interface, powerful Android System



Easy relocation, lightweight design



Higher production

**Our cobot will take over the repetitive and physically demanding tasks in your factory so workers can then perform jobs that generate more value.**

### Easy-to-integrate solutions for a wide range of applications.

Welding, packaging, palletizing, CNC & machine tending, pick&place, quality inspection, screwing, labelling, dispensing...

Check out our **Use Cases**



## Reach every corner with 7 axes.

Every cobot made by Kassow Robots has a 7th axis. This additional axis gives our cobots the highest possible degree of freedom. The user is able to control the position of the elbow, further increasing the safety. The robot's arm mimics the dexterity of the human arm. A feature that enables it to reach around corners.

From standard to sophisticated tasks our cobots are prepared to perform the infinite number of jobs required in factory automation operations.

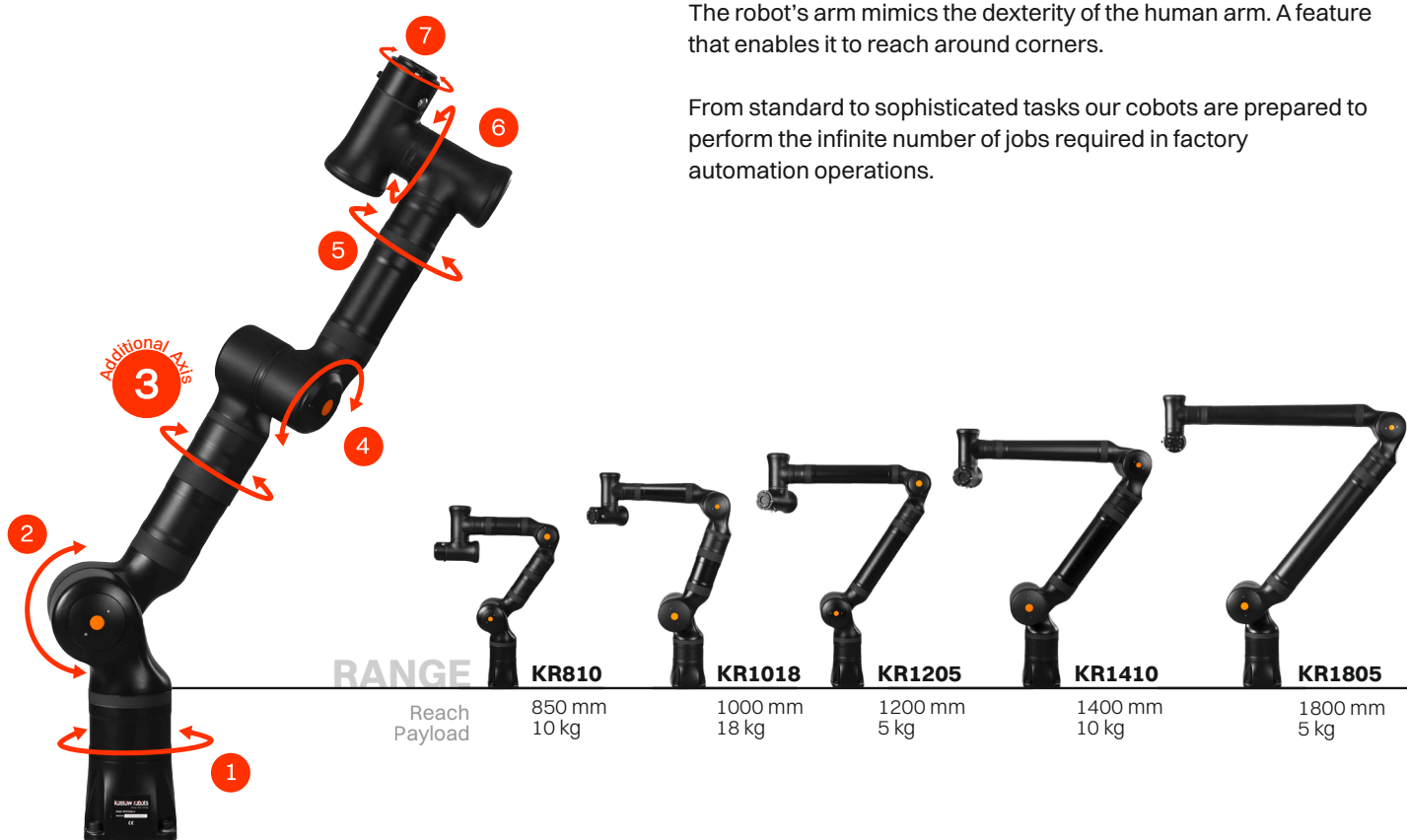

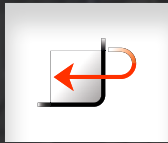

### Great maneuverability & around-the-corner reach

You can use the robot's arms in extremely confined spaces – and profit from the tremendous flexibility created by the 7th axis!



### Easy programming & operations

Divorce yourself from robot experts – program and operate the cobots yourself!

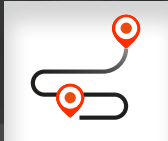

### High flexibility & fast relocation

Use the cobots in different places within your production facilities – the cobots' light weight and the plug and play approach makes it possible!



### Employees & cobots team up

Delegate the repetitive and unsafe jobs to your robot colleagues – and allow your employees to generate more added value elsewhere!



### Fast ROI & more satisfied employees

Our cobots pay for themselves quickly – boost your competitiveness with their high productivity!

## Dimensions & special product features.

Solid construction reflected by an all-aluminum surface and very strong materials. Our five models offer an exceptional durability, ensuring optimal performance in any setting. Compatible with a high variety of tools and a small base for an easy deployment in super confined spaces.

### DIMENSIONS OF THE BASE PLATE

#### KR1018, KR1410, KR1805

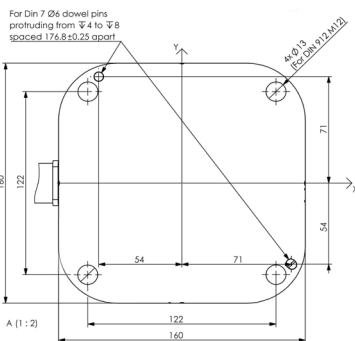

#### KR810, KR1205

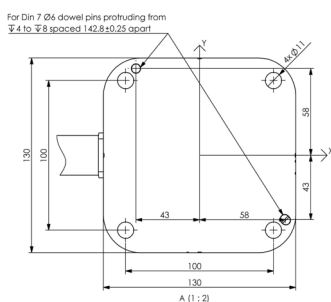

### ROBOT HEAD & PORTS

#### All cobot models

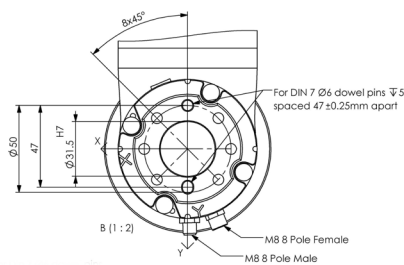

#### Connectivity

- Two I/O connectors with 24V/3A
- RS485 for connecting an end-of-arm tool
- 8 digital inputs/outputs

#### Free drive button

- Flexible waypoint programming
- Operation without a user panel

# KR Series Technical specifications

General specifications	KR810	KR1018	KR1205	KR1410	KR1805
Reach (mm)	850	1000	1200	1400	1800
Payload (kg)	10	18	5	10	5
Weight (kg)	26	36	27	37	40
Joint speed (deg/s)	225	163/225	225	163/225	163/225
Joint ranges (deg)	J2 and J4: -70°/+180°; J1, J3, J5, J6 and J7: ±360°				
Redundant absolute encoders on joints	Yes	Yes	Yes	Yes	Yes
Repeatability (mm)	+/- 0.03	+/- 0.03	+/- 0.03	+/- 0.03	+/- 0.04
Degrees of freedom	7	7	7	7	7
Footprint (mm)	130 × 130	160 × 160	130 × 130	160 × 160	160 × 160
Operating temperature (°C)	0-45	0-45	0-45	0-45	0-45
Body material	Aluminium				
Protection rating	IP54	IP54	IP54	IP54	IP54
Sound level (dB)	<65	<65	<65	<65	<65
Communication	Modbus (Master), Profinet (IO Device), ROS1/ROS2, KORD, TCP/IP, UDP				

Controller	KR810	KR1018	KR1205	KR1410	KR1805
Digital inputs dedicated E-stop & P-stop (Safety uses 2x I/Os for redundancy)	4	4	4	4	4
External 24V supply (A)	6	6	6	6	6
Relay outputs	4	4	4	4	4
Digital outputs (Safety supported in pairs)	8	8	8	8	8
Digital inputs (Safety supported in pairs)	16	16	16	16	16
Analogue I/O 0-10V	2/2	2/2	2/2	2/2	2/2
Analogue I/O 4-20mA	2/2	2/2	2/2	2/2	2/2

Power	KR810	KR1018	KR1205	KR1410	KR1805
Power consumption (with max. load; W)	400-600	400-1200	400-600	400-1200	400-1200
Supply voltage (VAC)	100-120 or 200-240	100-120 or 200-240	100-120 or 200-240	100-120 or 200-240	100-120 or 200-240
Supply current (A)	16	16	16	16	16
Supply frequency (Hz)	50/60	50/60	50/60	50/60	50/60



**Kasso Robots Aps**  
 Kajakvej 2,  
 2770 Kastrup/Copenhagen,  
 DENMARK  
 +45 20 24 09 95  
 sales@kassorobots.com  
 kassorobots.com

**kassow robots**  
 strong · fast · simple

Joining forces with

